

ASSEMBLY INSTRUCTIONS

Congratulations on your purchase of the RS7030 Tabletop Rack Stand. Please read the below instructions carefully. We hope you enjoy your new purchase!

PREPARATION

Remove the following from the box and identify all the parts:

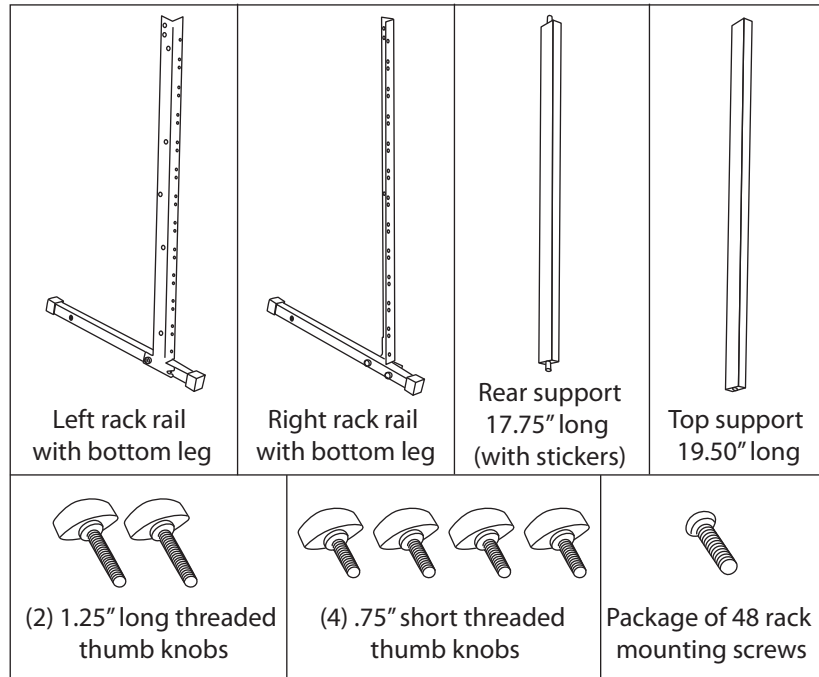

**On-Stage
Stands®**

© 2008 TMP, Inc.
Designed and engineered in the USA
Printed and manufactured in China
www.onstagestands.com

Continued on back

Continued from front

ASSEMBLING INSTRUCTIONS:

1. Take left and right rack rails and unfold them. Place left rack rail and right rack rail next to each other so that the equipment mounting holes face the inside.
2. Take one long threaded thumb knob and insert it through the rail brace and the front of the **LEFT** leg. Tighten thumb knob. **(Figure A)**
3. Repeat step 2 for right side.
4. Take rear support and insert it into the rear inside hole on the **LEFT** leg. **(Figure B)**
5. Take short threaded thumb knob and insert it through the rear outside hole on the **LEFT** leg. Thread into the rear support. Tighten knob. **(Figure B)**
6. Repeat steps 4 and 5 for right side.
7. Take top support. Align hole on the end of the top support with the top hole on the **LEFT** rack rail. Take short threaded thumb knob and insert it through the rack rail and top support. Tighten. **(Figure C)**
8. Repeat step 7 for right side.
9. Recheck all threaded thumb knobs to make sure they are tight before you install any equipment.

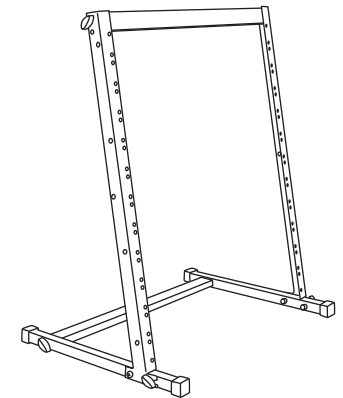
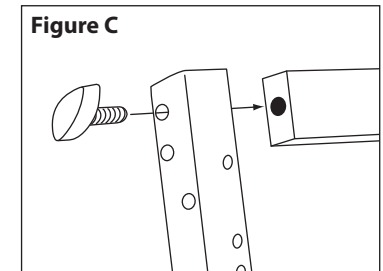
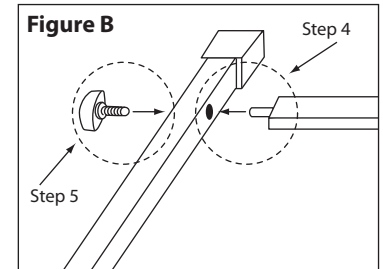
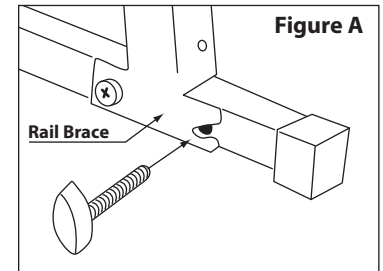

**On-Stage
Stands®**

© 2008 TMP, Inc.
Designed and engineered in the USA
Printed and manufactured in China
www.onstagestands.com